

TRAYSEALING THOUGHT & DESIGNED FOR YOU

by MECAPACK

TRAYSEALER O² 2500 HSK AUTOMATIC



HIGH SKIN



QUICK RELEASE



- + HIGH SKIN
- + RELIABILITY
- + ERGONOMIC

O² 2500 HSK

The traysealer for all your productions

HIGHLIGHT :

- Automatic tray sealer for HIGH SKIN application
- Top film gestion by servodrived chains device
- Preheating film station
- Protruding product possibility up to 95mm
- Flat board compatibility
- Ergonomic and full cleanable design
- Ergonomic solution with openable and manually locked top tool
- Pneumatocal sealing station with mechanical locking by rod

COMPATIBILITY
WITH CARDBOARD
PLATE

DIMENSION :

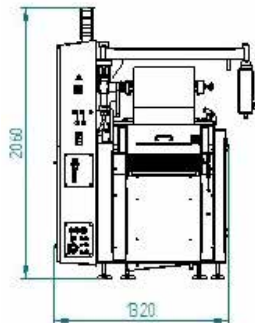
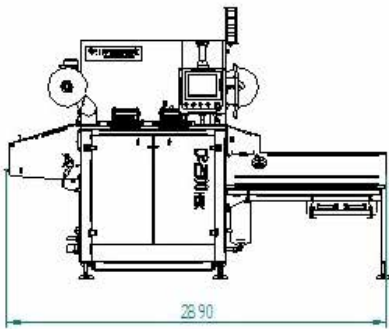

ENERGY :

Elec. : 10 KW

Pneu : 15m³/h at 6 bars

Water : 100L/h (integrated cooling unit in option)

PROCESS :

Skin with protrusion up to 95mm (Vacuum and gas compatibility)

SPEED :

Up to : 8 cpm

OPTION :

Vacuum and gas process compatibility | Integrated cooling unit | Spotted printed film | Loading conveyor extension | Tray / Flat board automatic and integrated denester | Integrated printing solution | Automatic filling solution | Integrated tray / Flat board inliner

INDICATIVE TRAY DIMENSION :

Pocket number	1	2
Lenght (mm)	320	250
Width (mm)	250	180
Hight (mm)	100	100

SECTORS :



This document and its content have non-contractual values